

Writing a Lab Report – A Working Example

Eric Myers*

*Advanced Physics Laboratory
Department of Physics and Astronomy
SUNY College at New Paltz,
New Paltz, New York 12561 USA†*

(Dated: 13 July 2023)

This document explains how to write a good lab report, while at the same time providing an example of the right style and layout.

I. INTRODUCTION

A well written lab report is important for a number of reasons. The lab report is a summary of your efforts and results. If the report is not clear then you may not get proper credit for your efforts, even if you produce good results. A lab report also collects together, organizes, and presents in a coherent fashion the disjointed jumble of facts and figures that are (quite properly) recorded in your lab notebook. Your lab report is how you convince your instructor that you understood the goals and methods of the experiment, that you did everything correctly, and that you obtained a valid and accurate result. Learning to write a good lab report will also prepare you to write a scientific paper for publication, which is how you convince your scientific peers that you understood the goals and methods of your work, that you did everything correctly, and that you obtained a valid and accurate result. If your paper is not well written your results may not be believed and you may not get the recognition you deserve for the work you have done.

The goal of this document is to explain how to write a good lab report, both by direct exposition and by serving as an example. As a start, notice how this paper begins with a paragraph which puts the subject in a wider context, and was then followed by a paragraph (the one you are now reading) which focuses the reader on the specific goals of this work. The first paragraph explains why the subject in general is important, while the subsequent paragraph explains the specific contribution of this paper to that important topic. You don't have to begin your papers this way, but it is a common way to do so, and a good way to get started if you don't have anything better in mind.

The rest of the opening of your paper can provide further background, perhaps a (brief!) historical overview of the subject, or a review of recent results. Reviewing

recent advances is a good way to put your own contribution in context and explain (or at least infer) why your own results are also important. Your introduction should be brief and to the point. Don't just quote or summarize lab handouts or review articles. It should be possible for someone to read your introduction and understand the general goals and methods of your experiment even if they have not read the lab handout.

For longer papers it is common (though not always necessary) to end the introductory section with a brief map of the organization of the rest of the paper. As an example, in the paper you are now reading we will begin with a discussion of how (and why) to organize your paper into separate sections. We will then go through those sections in more detail. Finally, we will close with some suggestions on how to typeset your paper using the REVTeX class of L^AT_EX macros or the T_EXsis macro package. It should be noted though that an outline paragraph like the one you are currently reading is really only appropriate for a longer paper than this. I have included it here only as a demonstration of the style.

II. ORGANIZATION

Scientific papers are easier to read when they are broken up into clearly defined sections. One reason this helps is that people do not always read scientific papers linearly. The reader might first go through the paper quickly from start to finish, but after that he or she may want to jump from one section to another to focus on particular details, or to try to understand how your work or your methods relate to their own work or to the methods they are familiar with.

How you choose the sections of your paper is up to you, and depends in part on the type of paper you are writing (theoretical versus experimental, brief report versus thesis). For a lab report there are some fairly standard sections: introduction, apparatus, method, data, analysis, results, conclusions, and a summary. You can (and should) use variations on this pattern when appropriate. For example, in some experiments the method is directly tied to the apparatus, so you would do better to describe both together in one section. Similarly, depending on whether or not it communicates your efforts well, you may want to combine the analysis and results

* MyersE@newpaltz.edu

† REVTeX also has a mechanism for adding acknowledgements to the paper. Depending on the journal format you choose they will show up as a footnote on the first page, or as an end note before the list of references. This is generally used to cite financial support from sources such as NSF, DoE, etc. This particular paper was *not* funded by the National Science Foundation under grant NSF-03-1234567

into a single section. Some labs are composed of several related experiments, not a single measurement. In that case it makes sense to have a separate section for each separate experiment. One section should never be omitted: the summary. You should always end your paper with a separate section which summarizes what you have done, reviews your overall results, and states the conclusions you wish the reader to draw from them. It is okay to say the same thing in your summary that has already been said in the body of the paper. Some redundancy is good, because some redundancy is useful to reinforce and elaborate on ideas; but too much redundancy can be distracting or even annoying.

The end of your paper is also the appropriate place to state what you think are the directions for further fruitful research. (Sometimes this is phrased as "we intend next to investigate thus-and-such", but you should only say it that way if you really do intend to do the work.) But such statements are not required.

Supplementary information, such as complicated derivations or computer code, should be included at the end of the paper in appendices. For more discussion on this point please see the Appendix.

A. The Title Page

The title page of your report should include a clear and descriptive title for your paper, the names of all authors, the affiliation of the authors, and the date. The title page will also have a brief summary paragraph, called an abstract. The title page of a physics paper published in an APS journal can also have one or more PACS codes which help classify the topic of the paper. (PACS stands for "Physics and Astronomy Classification Scheme.")

You should keep in mind that the "title page" may not take up an entire page. When you print a draft or "preprint" version of your paper the title page material may be on one page, with the body of the paper beginning on the second page, but when you print a final copy with two-column formatting the title material will appear at the top of the first page, and the text of the paper will begin immediately below the abstract.

1. The Abstract

Every scientific paper should have an abstract, which is a short summary of what the paper is about and why it is significant. The abstract is a separate single paragraph that states succinctly the goals of the reported work, the methods used (especially if they are new or different) and the results. The abstract should be able to stand by itself, separate from the paper. It might be the only thing listed in a conference program. At the same time, the paper should stand by itself without the abstract. The introductory section of your paper is completely separate from your abstract.

Writing a good, concise abstract can be difficult, but there is a well-known secret for making the job easier: write the abstract last, after the rest of the paper is completely finished. Then what you are writing can truly be a summary of the completed work because you have the completed work in front of you.

III. BACKGROUND AND THEORY

A scientific paper reports progress made on a particular problem or line of investigation. It is therefore part of a bigger story, and you need to put your own contribution in context with the rest of the story. Your paper should therefore have at least a paragraph and perhaps a whole section describing the background behind your experiment or work. You should describe earlier work on which your work is based or which is significant for your paper. For a laboratory course you should summarize the historical and scientific significance of the experiment you are performing. For a scientific research paper you need to clearly establish how your work fits in and why it is important enough to be reported.

If your paper is describing an experiment that you performed, you may need to provide the reader with a description of the theory behind the experiment so that they can understand your reasoning. Some calculations need to be presented later in your paper, as you analyze the data, but some calculations may need to be presented first, so that your reader will understand the goals and reasoning of your experiment. It is important to organize your paper so that a reader who is unfamiliar with the particular details of your experiment can still understand what you did and why you did it.

IV. APPARATUS AND METHODS

Your report should describe both the equipment and methods used in such a way that someone else working in the same field (or at least in the same lab) can reproduce the same experiment. You must strike a balance between giving too little detail and giving too much. For example, in published papers one does not usually need to list the model number for a particular piece of equipment unless that detail is important to the result. For a lab class like this it is preferred that you do list model numbers, so that the reader can be sure that he or she is reproducing your experiment exactly.

Likewise, you should describe your method with enough detail that it can be understood and reproduced, but common procedures such as checking that your batteries are not dead need not be explained in detail (or perhaps not at all). If a procedure is well known to your peers then you do not need to describe it in detail. For example, if you solve for the roots of a non-linear equation using the well known method of *regula falsi*?] then you need only mention the name of that method and cite

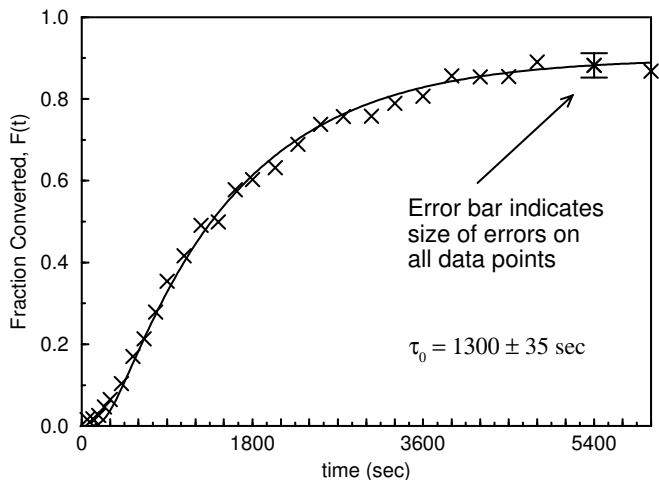

FIG. 1. Sample figure showing how to plot data along with a theoretical curve. In this case, because there are so many data points with the same uncertainty, only one representative error bar is shown.

a reference which describes it, but you do not need to take up space in your paper describing how it works.

V. DATA AND ANALYSIS

A. Presentation of Data

There is no need to list all of your raw data in your report, and indeed for some experiments it would be almost impossible to do so. Your goal is to convince your reader that you took good data carefully and accurately, so you may want to show a sample of your data, or some other kind of summary of your data to show that you did a good job. Plotting a graph is a good way to summarize your data visually without listing lots of numbers.

B. Calculations

Just as you don't need to show all your data, you also don't need to show all of your calculations. Your lab book is the place for all such details; your report should only contain a summary or description of how you processed and interpreted the data. Even so, your report does need to include enough of a description of what you have done that your peers (fellow students for a lab report, fellow scientists for a published paper) can reproduce it on their own. Complicated derivations can be put into an appendix rather than in the main body of your paper.

Simple equations can be written in the text in-line, like so: $E = mc^2$. Longer equations, especially those with subscripts and superscripts, should be set off from

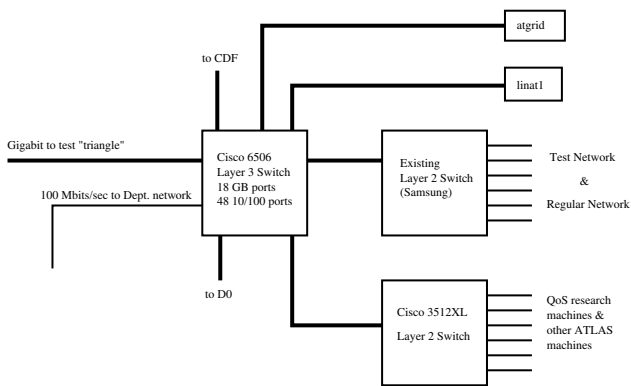

FIG. 2. Sample figure demonstrating some problems with including complicated graphics in a document.

the text as “displayed” equations, like this example:

$$\sigma_i \sigma_j = i \sigma_k \quad (i, j, k \text{ cyclic}) \quad (1)$$

Most displayed equations are numbered consecutively so that they can be referred to in the text, either by you or by your readers and reviewers.

When you describe a calculation you should explain the reasoning behind the steps, and display important intermediate results, but you don't need to show every step. (You can assume that your reader knows how to do algebra.) More complicated calculations that would otherwise interrupt the main flow of the paper can be put into a separate appendix at the end of the paper. (See the Appendix of this paper for further suggestions.) As an example of this style of presentation, Appendix ?? contains a derivation of the important consequences of Bohr's original model of the atom.

C. Figures and Tables

Sometimes words are not enough, and your argument is best put forward via drawings, graphs, pictures or tables. As the saying goes, “one picture is worth a thousand words.” Drawings, graphs, and pictures are all included in a paper as “figures”. Figures are numbered consecutively in the order in which they appear in the paper, which should be the order in which they are referred to in the text. Tables are numbered separately, also in the order in which they appear. Use tables sparingly, as you don't want to overwhelm the reader with too much unimportant detail. Besides, a graph often shows much more than just a list of numbers.

When a paper is printed in a journal the figures and tables are considered to be “floating” material which may end up at the top of the page, the top of another column, or even on another page. You should therefore not assume that the figure will be anywhere close to the text that refers to it. The best you can do is refer the reader



FIG. 3. Sample figure demonstrating that a bit-mapped image can be displayed as a figure.

to the figure as in “Figure ?? clearly shows ...” (whatever you wanted to point out). For manuscript typed on a typewriter or simple word processing program rather than typesetting software (such as \TeX) it is entirely acceptable and appropriate to put the figures and tables on separate pages at the end of your paper. If you do so, be sure that they are labeled with figure and table numbers and proper captions.

Each figure and table should have a brief caption, which includes the figure or table number and which tells the reader what the figure or table contains. The caption might explain the difference between the dashed lines and the solid lines, or mention that the view of the apparatus is from above, but any greater detail should be put in the body of the paper, not a caption. Don’t put important information in the caption which is not mentioned in the body of the paper. The caption is only supposed to identify the figure and aid the reader in interpreting it.

One convention to note is that figures traditionally have captions below the drawing or graph, while table captions go above the table.

Fig. ?? shows a sample figure which contains a graph of some data points (the “ \times ” markers) and a theoretical curve which may or may not fit the data well (notice the discrepancy near the origin). The caption is brief, with any elaboration put into the main text of the paper. One thing to note about this figure is that when it was originally created the size of the markers, the width of the lines and curves, and the typeface were all made slightly larger than one would normally think appropriate, so that the figure would be readable when reduced for the \LaTeX double column format.

Fig. ?? shows an example of what not to do. The drawing was originally created for a PowerPoint presentation. It was easy to read when projected on a large screen; It may also be relatively easy to read when this paper is printed in “preprint” format. However, since the drawing is fairly complicated and the lines are thin and the text is small, the figure is hard to read when it is reduced for double column output.

It is fairly easy to insert a drawing, graph, or picture into a \LaTeX document. The figure should be saved as an EPS (“encapsulated” PostScript) file. Programs like Matlab and Mathematica have an option which lets

TABLE I. Sample table showing AT&T Common Stock prices over several years. The values are from a sample table in *The \TeX Book*, [?] pg. 247. Note that table captions generally go *above* the table.

| Year | Price | Dividend |
|------|-------|----------|
| 1971 | 41-54 | \$2.60 |
| 2 | 41-54 | \$2.70 |
| 3 | 46-55 | \$2.87 |
| 4 | 40-53 | \$3.24 |
| 5 | 45-52 | \$3.40 |
| 6 | 51-59 | .95 |

you save graphs directly as EPS files. Other graphic files can be easily converted to EPS form. Fig. ?? is an example of a bit-mapped image which has been converted from a JPEG file to an encapsulated PostScript (EPS) file using the Unix `xv` program.

Table ?? is an example of a simple data table.

D. Error Analysis

There are several kinds of “errors”, though it is really more accurate to refer to them as “uncertainties.” It is important to distinguish the difference between accuracy and precision. In a laboratory class it is relatively easy to figure out the accuracy of your result: You use the data you have collected to compute a value, such as the charge of an electron or the lifetime of a muon. You can go to a well recognized source, such as the Particle Databook,[?] and look up the accepted value of this quantity. A measure of the accuracy of your result is the difference between your value and the accepted value.

But for several reasons it is more important to know the precision of the experiment, not just the accuracy. To determine the precision you measure or estimate the probable error (ie. uncertainty) in your initial measurements. Then you use the rules for propagation of statistical uncertainties (as described in Bevington’s book[? ?]) to determine what the likely statistical uncertainty is in your final value.

In the end, you will often summarize your result as something like “we have determined that the value of blah-blah is $x.xxxx \pm y.yyyyy$,” where $x.xxxx$ is the final value you have computed, and $y.yyyyy$ is the statistical uncertainty (standard deviation of the mean). Here $y.yyyyy$ is a measure of the precision of your result, not the accuracy.

Without knowing the expected precision of the experiment you really don’t know what makes for good accuracy. You really need to compare the two (take the ratio if you like). If the experiment went as it should then the accuracy should be somewhere near or within the precision, but not a lot smaller than the precision. If the accuracy is much smaller than the expected precision then

you just got lucky (or overestimated your uncertainties, which is also not good). If the accuracy is much larger than the precision then something probably went wrong with the experiment.

Another reason the precision can be more important is that you may not even be able to know the accuracy. This is always true in a research setting when you are measuring something for the first time. Then there is no “accepted” value – your experiment will be the only value available – and the precision is the only estimate you will have of the possible error (uncertainty) in your result.

And yes, computing how the uncertainties propagate from the initial inputs to the final result is lots more computational work than just computing the final result. That’s just the way it is, part of the job.

Finding out how uncertainties in your data propagate to the final result can also help you design a better experiment, because it will show you which quantities need to be measured more carefully, and which quantities don’t matter so much. Suppose you measure a , b , and c to compute $V = abc$. Using the standard rules to propagate the statistical uncertainties you would add the *relative* uncertainties in quadrature (that is, square the relative uncertainties, add the squares, and then take the square root to get the relative uncertainty of the result). But suppose that a and c are known to 2% relative uncertainty, while b is known only to 15% relative uncertainty. Then the uncertainty in b will almost totally dominate the overall uncertainty. It would then be much more important to improve the precision of your measurement of b than to put more effort into better measurements of a and c . But you won’t know which input is the “weakest link” in the chain of analysis until you look at how the uncertainties of the inputs influence the overall uncertainty of the result.

The point of all this is that you should pay close attention in your experiments and lab write-ups to how the (often estimated) uncertainties in your inputs lead to an uncertainty in the final value. You should estimate the size of every possible uncertainty to see how it influences the uncertainty of the final result. (And you can ignore the errors if they are clearly much smaller than much larger errors in other input quantities.) You should report the uncertainty of your result as the precision. Your final value doesn’t mean much without a measure of its uncertainty, just as the final value isn’t complete without stating the units it is measured with.

VI. CITATIONS AND REFERENCES

Any outside source of information that was used to prepare your report or to enable you to perform your work should be properly cited. In physics papers the usual method of citation is to assign a sequential number to each referenced work in the order they are cited, to put that number in the text at the point of citation, either

as a superscript or in square brackets, and to then list all references in order at the end of the paper.

At a minimum a reference must tell the reader how they themselves can obtain the cited work, so that they can see what you saw and perhaps even use it in their work. Ideally you will also include who wrote the article or book you cite (they deserve credit for their work) and when it was published or created. Thus a reference to a book would have the names of the authors, the title of the book, and the year of publication. For a book you generally also include the publisher, the edition used, if there is one, and a page number if you are referring to a particular part of the book. An example is shown at the end of this paper for both editions of Bevington’s book on error analysis.[? ?]

Journal articles are referred to by author, the name of the journal, the volume of the journal (printed in bold face, or underlined on a typewriter), the page number on which the paper starts, and the year in parentheses. To save space journal names are abbreviated, and for articles with more than three authors only the first one is named, followed by “*et al.*”. Journals also save space by not including the title of the article, but for this course it is useful to have the title of the article included in the list of references. An example is shown at the end of this paper for an article in the *Annals of Mathematics*.[?] If you are using BibTex (see below) then you can include the `'longbibliography'` class parameter to cause article titles to be shown.

References to web pages should include the URL (the web address) and the author’s name (if you know it) and the title of the web page (either as displayed at the top of the page or in the title bar at the top of the browser window). Because information on the web can change you should also include the date that you accessed that page. See the examples in the list of references at the end of this paper. [? ?]

In general, citing Wikipedia is not discouraged for general technical topics, but some readers (and teachers) consider it a weak source. Instead, a good Wikipedia article will cite the sources it draws on, and you can go directly to those sources and read them, and then cite them in your own paper instead.

A reference to an unpublished work such as a pre-print or lab report should include the name(s) of the author(s), the title of the paper (this is sometimes omitted to save space, but in this course you should include it), the date, and the institutional reference code if there is one. An example is shown at the end of this paper for this paper itself,[?] which has code number VC-MPL-2003-47. But a pre-print available on the web should be cited by URL, as described previously.

Unpublished information which has been made available to you personally by someone else should be referenced as “private communication”.[?] It is useful to mention the date of the communication, if you can. You should try to avoid this kind of citation whenever possible, because your reader cannot get the same informa-

tion for themselves. But sometimes it is necessary to give proper credit to someone who gave you useful information.

While it's possible to create the list of references "by hand" at the end of your paper, there is a tool called BibTeX[?] which is very useful for creating the list of references for one or more than one paper from a common list of sources. The general idea is that you create a file ending in `.bib` that contains all the details about the sources you wish to cite, in any order. An example called `modlab.bib` is included with the materials for this paper. You then run the `.bib` file through the BibTeX program[?] to produce a `.bbl` file (and a log file ending in `.blg`), and the `.bbl` file is read in to define your references the next time you run your manuscript file through LaTeX. You then insert the list of references at the end of your paper using the `\bibliography` command.

VII. SUMMARY AND CONCLUSIONS

It is important to end your paper with a summary which gives a review of what you have done (not the details, just an overview) and summarizes your results. If the end result of your work is a numerical value (e.g. the charge on electron), then you should restate here the value you have found, as well as the accuracy and un-

certainty of your result. Don't worry about saying something you have already said in the body of the paper, this is the place for repeating what you think is important to make sure that your reader recognizes the main point of your paper and the end result of your efforts.

Do not underestimate the importance of this section. Your paper may cover a lot of ground, but if you don't tie it all together at the end you can leave your reader feeling like you just did a few haphazard things without much purpose.

ACKNOWLEDGMENTS

The end of your paper is also the appropriate place to thank anybody who has helped support your work, either financially, technically, or personally. If someone makes a contribution to the work which helped make it possible but is not sufficient for authorship then you should be sure to mention them at the end of your paper. In that spirit, I would like to thank Dan Lawrence of Vassar College for all the assistance he rendered in getting Physics 201 up and running. I would also like to thank my students in that course for helping me organize this material, and for helping debug the installation of REVTeX on the Mac OS X platform.

-
- [?] T. Regula and J. Falsi, "Method of solving non-linear equations with one unknown," *Ann. of Math.* **30**, 61 (1806).
 - [?] Donald Knuth, *The TeXBook* (Addison-Wesley, 1970).
 - [?] Particle Data Group, "Review of particle properties," *Phys. Rev. D* **50**, 1173–1825 (1994).
 - [?] Philip R. Bevington, *Data Reduction and Error Analysis for the Physical Sciences*, 1st ed. (McGraw Hill, 1969).
 - [?] Philip R. Bevington and D. Keith Robinson, *Data Reduction and Error Analysis for the Physical Sciences*, 2nd ed. (McGraw Hill, 1992).
 - [?] Eric Myers, "VC Physics 201 - additional notes and links," <http://www.spy-hill.net/~myers/vassar/201/> (2003), accessed: 13 July 2023.
 - [?] "How can I use BibTeX to cite a website in LaTeX?" (2023), <https://bibtex.eu/faq/how-can-i-use-bibtex-to-cite-a-website/> [Accessed: 13 July 2023].
 - [?] Eric Myers, "Writing a lab report – a working example," (2003), VC-MPL-2003-47.
 - [?] James Lombardi, (2003), private communication.
 - [?] "BibTeX: The essential tool for managing your bibliographies," (2023), <https://bibtex.eu/>.
 - [?] In TeXShop select BibTeX instead of PlainTeX or LaTeX.

Appendix A: When to Use an Appendix

Sometimes you will want to include additional material in your paper that is outside of the main line of your argument, or is so detailed that it would distract from your main point. In this case it is appropriate to put the additional material in an appendix at the end of the paper, and then refer the reader to that appendix.

A good example of something appropriate for inclusion as an appendix is a complicated derivation of an important equation. You want to include the derivation in your paper, but working it out in the body of the paper would take away from the main argument. You can instead simply use the equation and go on with the main argument, but refer the reader to the appendix for the details.

Listings of computer programs used in your work are also properly included at the end of the paper as appendices. You would only include such listings if you wrote the code for this paper and it isn't available any other way (eg. on a web page).

Appendix B: The Bohr model of the atom

Rutherford's model of the atom supposed that the electrons of an atom orbit the nucleus much like the planets orbit the sun, because both are subject to a $1/r^2$ force.

But even Rutherford recognized that this arrangement would be unstable, because an accelerated charge would give off electromagnetic radiation and spiral in to the nucleus. Bohr modified Rutherford's model first by assuming only circular orbits (which was not realistic), and second by making the *ad hoc* assumption that the angular momentum could only have certain discrete amounts, integer multiples of \hbar :

$$L = n\hbar \quad n = 1, 2, 3 \dots \quad (\text{B1})$$

Bohr then showed that this implied that i) only certain orbital radii are possible, and ii) only certain energy levels are allowed.

To see how only certain orbital radii are allowed first consider the Coulomb force between the electron and nucleus as the source of the centripetal force:

$$F_C = k \frac{qq}{r^2} = \frac{mv^2}{r} \quad (\text{B2})$$

Using the quantization condition in Eq. ?? with $L = mv$

one can determine the velocity of the electron to be

$$v = \frac{n\hbar}{mr} \quad n = 1, 2, 3 \dots \quad (\text{B3})$$

Substituting this into Eq. ?? and solving for the radius r gives:

$$r_n = \frac{n^2 \hbar^2}{kq^2 m} \quad n = 1, 2, 3 \dots \quad (\text{B4})$$

Only these allowed radii are allowed in Bohr's model.

The quantized energy levels are easily obtained using the classical expression for the energy of the system,

$$E = \frac{1}{2}mv^2 - \frac{kq^2}{r} \quad (\text{B5})$$

and substituting the velocity from Eq. ?? and allowed radii from Eq. ?.?. The result is

$$E_n = -\frac{1}{2} \frac{mk^2 q^4}{\hbar^2 n^2} \quad (\text{B6})$$

This is completely calculable in terms of the fundamental constants k and \hbar and the known charge and mass of the electron.

Appendix C: Computer Code listing

```

#!/usr/bin/env python2.7
#
# Example of using multiple segments of data from a single LIGO HDF5 file.
#
# Eric Myers <EricMyers47@gmail.com> - 21 June 2015
#####

import numpy as np
import readligo
import matplotlib.mlab as mlab

## Open the "frame" file (.hdf5 not .gwf) and read the strain
## and the time arrays

fileName = 'ligo_data.hdf5'

print "Reading file ",fileName,"..."
strain, time, channel_dict = readligo.loaddata(fileName)

ts = time[1] - time[0]      #-- Time between samples
fs = int(1.0 / ts)         #-- Sampling frequency (should be 4096)

## Get the list of segments in this file

segList = readligo.dq_channel_to_seglist(channel_dict['DEFAULT'], fs)
print "There are ",len(segList)," segments in this file."

## Loop over all the segments.
## Each time through the loop segSlice is set to a Python slice object
## which can be used to get a subset of the strain data for just that segment.
## (Also, remember that Python uses indending for grouping.)

i=0
for segSlice in segList:
    i = i + 1
    print " "
    print i,") Segment list: ", segSlice

    ## Use the slice object to select the subset of the strain array
    ## and time array for this segment

    strain_seg = strain[segSlice]
    time_seg = time[segSlice]
    Nseg = len(strain_seg)
    print "   Number of samples: ", Nseg, "(for ", Nseg/fs," seconds ) "

```